

## 16603/16604 Series Noise Source

(10MHz to 18GHz/26.5GHz/40GHz/50GHz)



**Ceyear Technologies Co., Ltd.**

## Product Overview

The noise source is a device that can generate a random continuous spectrum signal. A well-operated noise source should have a stable output noise power and a homogeneous power spectral density within a specified frequency band. We, Ceyear Technologies Co., Ltd ( CEYEAR as follows) provide a variety of solid-state coaxial noise sources in the frequency range of 10MHz to 50GHz, namely, smart and standard series, which have the advantages of wide frequency coverage, small output voltage standing wave ratio (VSWR) , and excellent flatness of output excess noise ratio, etc.

The smart noise source adopts the I<sup>2</sup>C bus-technology to realize the automatic download and improve the measurement speed. Equipped with digital temperature sensor, it is convenient for the host to automatically monitor the change of ambient temperature and can be used to correct the temperature of the noise figure measurement and improve the measurement precision. Standard noise source requires +28V pulse drive voltage.

The noise source and noise figure analyzer are used together to provide a complete solution for the measurement of the noise figure of microwave millimeter wave frequencies. Ceyear has established a corresponding frequency band noise source calibration system to calibrate the excess noise ratio of noise source regularly.

## Main Characteristics

- Wide frequency coverage and excellent flatness of output excess noise ratio
- The value of excess noise ratio can be automatically loaded after the smart noise
- source connecting with noise figure analyzer
- Real-time temperature detection
- High-accuracy microwave millimeter-wave noise source ENR calibration system for
- accurate calibration

### **Wide frequency coverage and excellent flatness of output excess noise ratio**

The upper frequency limit of the series coaxial noise source can reach 50GHz. The frequency coverage is wide and the flatness of excess noise ratio is good.

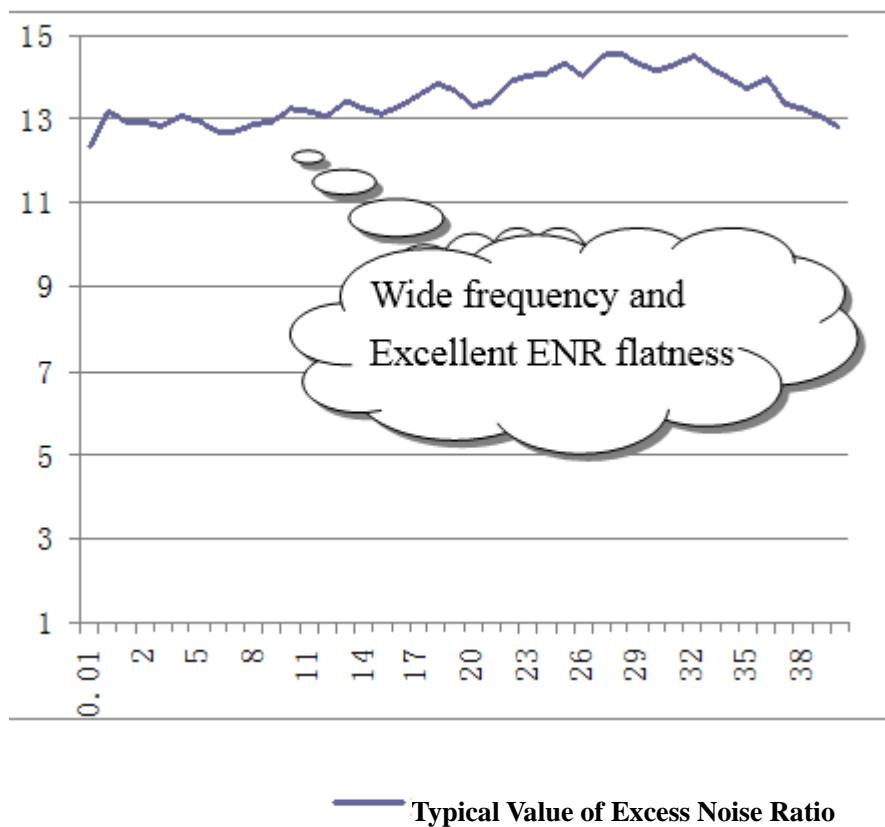

**Excess Noise Ratio can be automatically loaded after the smart noise source connecting with noise figure analyzer.**

Smart noise source adopts I2C bus-technology with built-in electronic memory to store the data of frequency-dependent excess noise ratio.

#### **Real-time temperature detection**

The smart noise source has a built-in digital temperature sensor, which can monitor the real-time change of the ambient temperature, and can be used to correct the temperature of the noise figure measurement and improve the measurement precision.

#### **High-accuracy microwave millimeter-wave noise source ENR calibration system for accurate calibration**

The microwave and millimeter wave noise source calibration system is established and the automatic test software is developed to realize the automatic calibration of excess noise ratio of the noise source and to facilitate the periodical verification of the noise source.

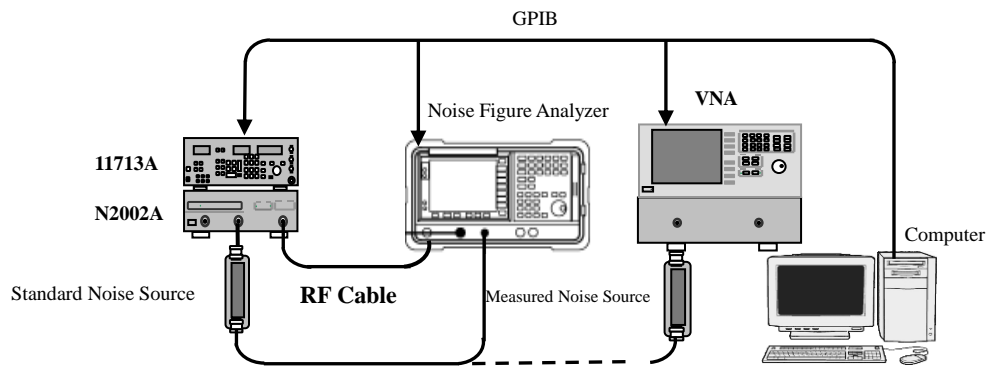

**A calibration system for the excess noise ratio of microwave wave noise source**

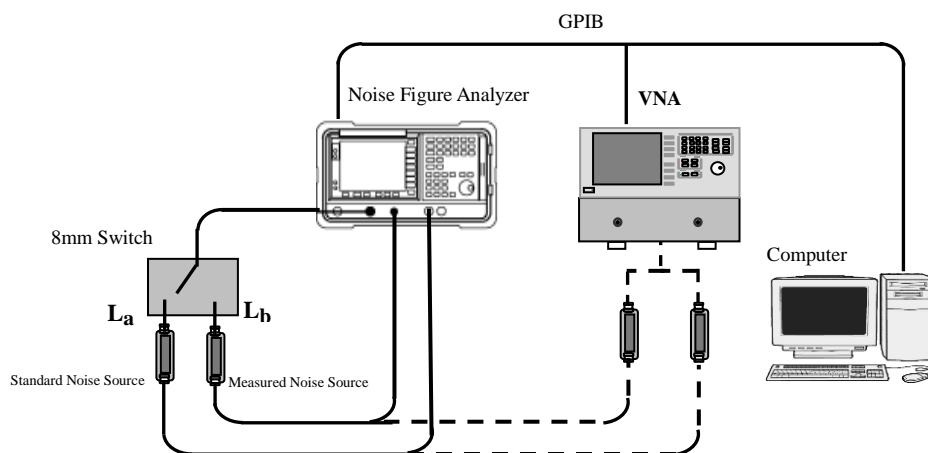

**A calibration system for the excess noise ratio of millimeter wave**

## Technical Specifications

16603 Series Noise Source					
Types	Frequency Range	Excess Noise Ratio Range	Output VSWR	Output Interface Types	Driver Interface
16603DA	10MHz to 18GHz	5dB to 8dB	<1.30: 1	3.5mm (Male)	Standard Driver Interface
16603DB	10MHz to 18GHz	14dB to 17dB	<1.30: 1		
16603EB	10MHz to 26.5GHz	12dB to 17dB	<1.35: 1		
16603FB	10MHz to 40GHz	12dB to 19dB	10MHz to 18GHz <1.35: 1	2.4mm (Male)	
			18GHz to 40GHz <1.45: 1		
16603HB	10MHz to 50GHz	10dB to 19dB	10MHz to 18GHz <1.35:1		
			18GHz to 50GHz <1.50:1		
Size	WxHxD=30mmx21.5mmx137mm				
Weight	0.17kg				

16604 Series Smart Noise Source					
Types	Frequency Range	Excess Noise Ratio Range	Output VSWR	Output Interface Types	Driver Interface
16604DA	10MHz to 18GHz	5dB to 8dB	<1.30: 1	3.5mm (Male)	Smart Driver Interface
16604DB	10MHz to 18GHz	14dB to 17dB	<1.30: 1		
16604EB	10MHz to 26.5GHz	12dB to 17dB	<1.35: 1		
16604FB	10MHz to 40GHz	12dB to 19dB	10MHz to 18GHz <1.35: 1	2.4mm (Male)	
			18GHz to 40GHz <1.45: 1		
16604HB	10MHz to 50GHz	10dB to 19dB	10MHz to 18GHz <1.35:1		
			18GHz to 50GHz <1.50:1		
Max. Size	WxHxD=52.5mmx33.5mmx125.5mm				
Max. Weight	0.25kg				

## Ordering Information

- Main Unit: 16603/16604 Series Noise Source
- Standard Configuration

No.	Types	Explanation
1	Noise Source Drive Cable	Multi-core Cable: used for the connection of smart noise source and noise coefficient analyzer; BNC (Male)-BNC (Male) Cable: used for the connection of standard noise source and noise coefficient analyzer.
2	Excess Noise Ratio Calibration Data	-
3	Manufacturer's Certificate	-

- **Options**

Types	Description	Functions
16603/4-H01	711XX Series Coaxial Adapters	Used for the adaptable connection between noise sources and noise figure analyzers

**Ceyear**  
Focus on Measurement  
Explore the Future

**4TECT**  
ООО «4TECT»  
Телефон: +7 (499) 685-4444  
info@4test.ru  
www.4test.ru